

**LIMITED SLIP
DIFFERENTIAL**

**INSTALLATION
MANUAL**

-IMPORTANT APPLICATION NOTE-

Before installing the ring gear and pressing the bearings on to the differential, the following two (2) items need to be checked:

1. Ensure that your axle shaft mates with the differential side gear. Some models have different spline counts depending on the year of manufacture.
2. Check the differential flange position (bearing shoulder to flange face) to ensure that it is correct. You may compare it to your old one. The differential flange position depends only on the gear ratio that you are using. This flange position may change at certain gear ratios. Some aftermarket ring gear and pinion sets specify the differential case "series" that is required.

If you feel that you have the wrong differential for your application, contact your **place of purchase** and make the necessary arrangements to exchange the differential for the correct one.

Once the differential has had bearings and/or a ring gear installed, it can no longer be considered new and therefore **cannot** be exchanged for a new one.

-IMPORTANT LUBRICANT NOTE-

The Auburn Gear limited-slip differential design has been extensively tested with high quality **non-synthetic 80W90** hypoid oils treated with **GM or Ford friction additives** (3 oz. of additive will treat 1 quart of oil). To avoid differential clutch chatter (noise) and for optimum performance, use the oil and additive described above. Use of other additive and oil types may cause differential clutch chatter.

- **Ford Part Number: C8A219B546A**
- **GM Part Number: 1052358**

PINION SHAFT MODIFICATION

Certain "C" clip axle applications with high gear ratios will require pinion shaft modification due to the thickness of the ring gear. The thick ring gear will prohibit the pinion shaft from being removed making "C" clip installation impossible. Use the following procedure to modify the pinion shaft.

1. Modification to be 90° to the pinion shaft lock screw hole as shown. It is recommended that this be accomplished through grinding.
2. Remove sharp edge from modified section by buffing.
3. Pinion shaft should not be re-hardened after modification.

Reinstall the pinion shaft prior to installing the ring gear. With the ring gear installed, rotate the pinion shaft so that the ground flat is parallel to the ring gear face. Pull the pinion shaft outward as far as possible. Install an axle shaft and check that the end of the axle will pass the end of the pinion shaft.

An alternate solution is to index the ring gear on the differential until a tooth space is directly in line with the pinion shaft. In many cases, this will allow the pinion shaft to be removed without modification.

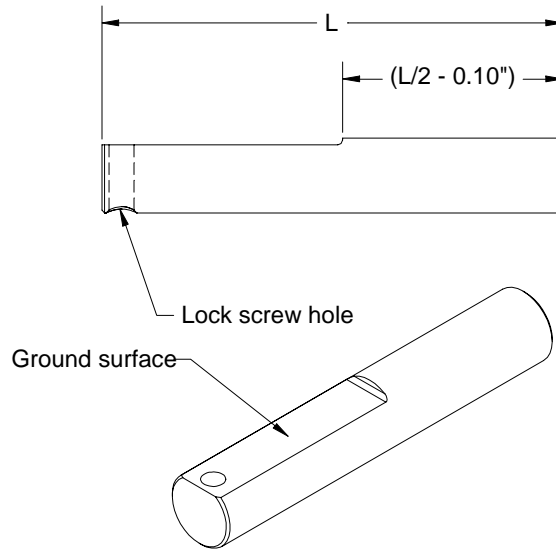

CAUTION:

During installation of the axle shaft and "C" washer, care should be taken as not to pry against or on the spring retainer plates. This may cause damage to the spring retainer.

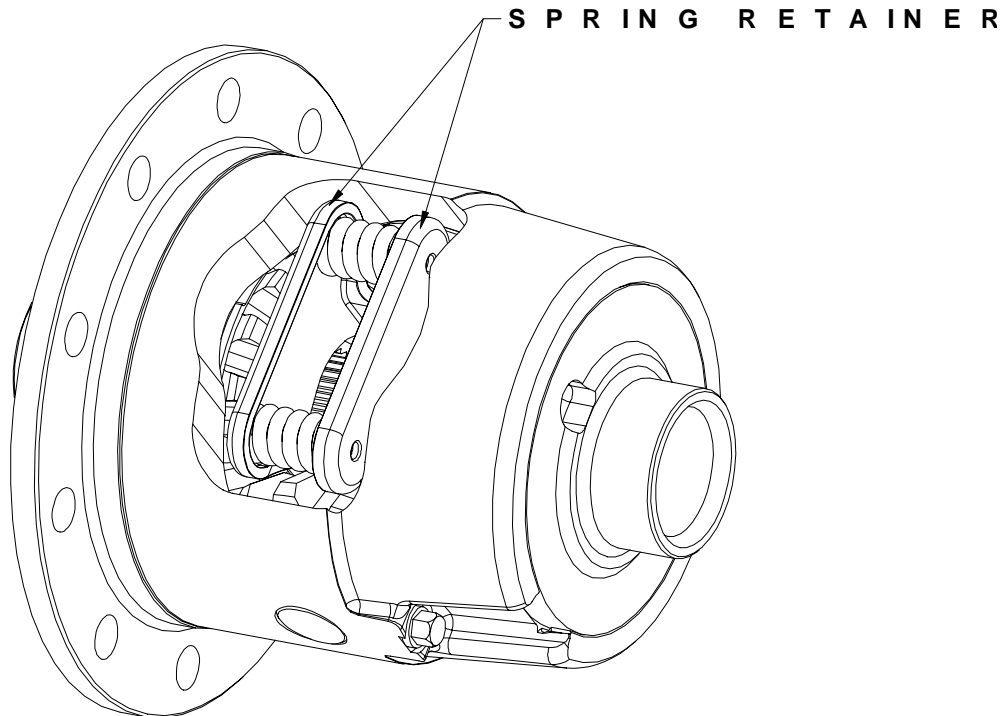

SPECIAL NOTES

- **Ford 8"** applications require the use of the following carrier bearings:
 - LM 102949 (Bearing Cone)
 - LM 102910 (Bearing Cup)
 - Same bearings used in certain Ford 9" applications
 - **Ford 8" & Ford 9"** applications require the use of ring gear bolts from an open type differential, Ford Part Number D802-4216-B. Ford limited-slip type bolts are too long.
 - Be sure to **torque** the pinion shaft lock screw to **20 - 25 lb-ft**. The lock screw is not torqued prior to shipment on most models.
 - **Chrysler 8-3/4** applications require the use of the following carrier bearings (Stock bearing for 1969-1973 applications):
 - LM 104949 (Bearing Cone)
 - LM 104912 (Bearing Cup)
 - **Ford 7.5** applications require special "C" washers, which are supplied with the differential.
 - Some **AMC 20, Dana 44, and Chrysler 8-3/4** applications require the use of an axle spacer, which is included with these units.
 - Some applications use a **Tone Wheel** for the **anti-lock braking** system. In most instances, this Tone Wheel is fitted to the outer diameter of the ring gear flange. Remove the Tone Wheel from the original differential and install onto the new differential. Refer to vehicle service manual for detailed removal and installation procedures.
- CAUTION:** Be careful not to damage **Tone Wheel** teeth during removal and installation.
- NOTE:** **GM 7-5/8** applications use two (2) different Tone Wheels, depending on the differential case series.
- 3.08:1 & down gear ratios - Series 2 case
 - 3.23:1 & up gear ratios - Series 3
- **Chrysler 8-1/4** applications require modification to the axle housing as shown to provide clearance for the differential case. Clean housing after grinding.

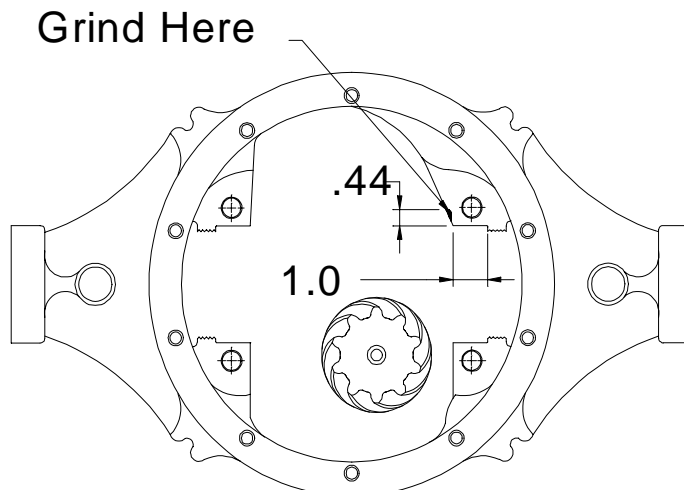

LIMITED-SLIP OPERATION

Limited-slip differentials are designed to transfer torque to the high traction wheel. This is accomplished through a torque sensing clutch arrangement with preload springs.

During turning maneuvers, the clutches are forced to slip allowing the wheels to rotate at different speeds.

The differential is a fully automatic torque sensing design. Torque is instantly routed to the wheel with traction. In some extreme situations, the low traction wheel may begin to spin. It should be understood that spinning the low traction wheel faster does not 'engage' the differential. In these situations, slight application of the emergency brake will increase the torque transferred to the high traction wheel.

INTRODUCTION

There are two (2) items of concern when installing a differential.

- Ring and Pinion Backlash
- Differential Carrier Bearing Preload

These items are typically adjusted by means of shims or threaded adjusters. The shims or adjusters will determine the position of the ring gear, which determines the backlash of the ring and pinion set. When installing a differential, the backlash should be set to the original backlash setting, which was measured prior to disassembly. To increase the backlash, adjust the shim packs or threaded adjusters to move the ring gear further away from the drive pinion gear. To decrease backlash, move the ring gear closer to the drive pinion gear.

Bearing preload refers to the amount of interference (press) fit of the differential case and bearings into the carrier housing. Adjust the bearing preload by adding or removing shim pack thickness or by tightening or loosening the threaded adjusters. Too much bearing preload will cause premature bearing failure. Insufficient bearing preload will allow the differential to 'walk' in the housing causing damage to the ring and pinion set and other components.

These instructions are intended as an aid for the experienced automobile mechanic in properly installing the limited-slip differential. It is expected that the installer be equipped with the proper tools, equipment, and experience before attempting the installation.

It is necessary to have an extensive selection of shims or adjustable shim packs to properly install the differential. Threaded adjuster applications do not require shims.

MAINTENANCE

It is recommended that the axle lubricant be changed every 7500 miles or as required by your vehicle's service schedule. Lubrication breakdown can lead to accelerated wear to all rear axle components. See **IMPORTANT LUBRICATION NOTE** on page 2 for oil and additive requirements.

INSTRUCTIONS

1. Raise and support vehicle.
2. Remove wheels and brake drums or brake rotors.
3. Drain lubricant from carrier and remove cover.
4. Remove axle shafts from housing.
 - A. "C" clip axles
 - 1) Remove pinion shaft lock screw and pinion shaft.
 - 2) Push flanged end of axle shaft toward the center of the housing and remove the "C" clip from the button end of the axle shaft. Repeat for other axle shaft.
 - 3) Remove axle shafts from housing. Be careful not to damage the oil seals.
 - B. Non-"C" clip axles
 - 1) Remove axle shaft bearing retaining plate nuts and remove the retaining plate.
 - 2) Use a slide-hammer to remove the axle shafts. Be careful not to damage the oil seals.
5. For removable carriers, disconnect the drive shaft from the pinion yoke and remove the third member from the axle housing.
6. Prior to further disassembly, measure and record the ring and pinion backlash. Mount an indicator as shown in Figure 1. Hold the drive pinion stationary and rotate the ring gear in both directions to measure the amount of backlash or free play. Check the backlash at three to four points around the ring gear and record for later use.

Figure 1

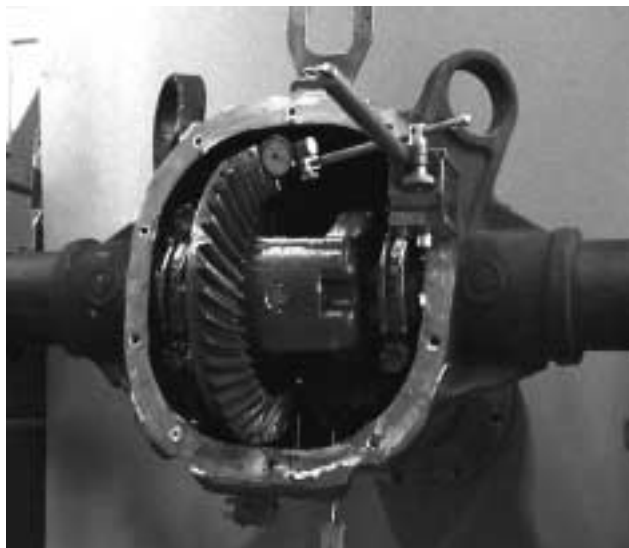

7. Mark bearing caps "R" and "L" to make sure they will be reassembled in their original position.
8. If equipped with adjuster nuts, remove adjuster nut locks and loosen adjuster nuts.
 - Chrysler tool C-4164
 - Ford tool T70P4067-A
9. Remove bearing cap bolts and bearing caps.
10. Remove differential case. It may be necessary to use a pry bar as shown in Figure 2. Exercise caution when prying on the carrier so that the gasket sealing surface is not damaged. Place shims/adjuster nuts and bearing cups with their respective bearing cap.

Note: Adjuster nuts will stay in the housing in some axles.

Figure 2

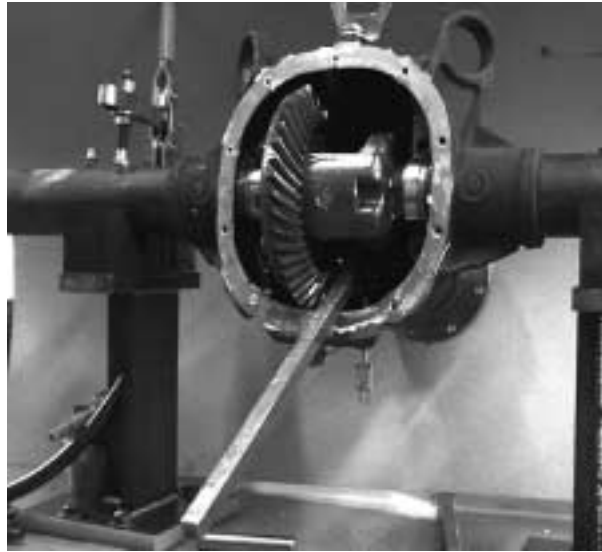

11. Remove and discard the ring gear bolts. With a non-metallic hammer or brass drift punch, drive the ring gear loose from the differential case pilot and remove.
 12. Remove anti-lock brake tone wheel if applicable. Consult vehicle service manual for proper procedure.
 13. Remove differential bearing cones from the differential using the proper bearing puller and adapter. See Figure 3.
 14. Clean all parts in a suitable cleaning solvent and dry thoroughly. Clean axle housing by pushing a clean rag through the axle tube with a wooden rod. Push the rag from the end of the axle tube to the center of the axle housing. Wipe down the inside of the housing with a clean rag.
- CAUTION:** Do not spin-dry the bearings with compressed air. Serious injury may result.
15. Remove any burrs from all machined surfaces in the axle housing, bearing cap and ring gear.
 16. Inspect axle shaft bearing surface, bearings and seals. Replace if needed.

Figure 3



17. Inspect differential bearings and replace if needed. Always replace both the cup and cone as a set from the same manufacturer.
18. Thoroughly clean the differential bearing hubs and ring gear mounting flange prior to installation of the bearings and ring gear.
19. Install the differential bearing cones onto the bearing hubs of the differential case using the proper installation tool. See Figure 4.

Note: Many Dana applications use shims between the bearing cone and the differential case bearing hub shoulder. The bearing cones must be removed to make adjustments to the shim pack thickness.

Figure 4



20. For adjuster nuts, skip to Step 23.

21. Install differential with the bearing cups and shims into the differential housing. Adjust the shim pack as necessary to create a slip fit of the differential into the differential housing. A slip fit is the thickest shim pack that can be installed by hand with slight resistance. It will be necessary to rotate the differential case after each shim thickness change to seat the bearings.
22. Remove the differential from the differential housing. Measure the combined thickness of the shims. This total shim thickness is what is needed for installing the differential (prior to adding preload to the bearings).
23. Heat the ring gear and anti-lock tone wheel (if applicable) with a heat lamp or by submersing in hot water. Do not exceed 300°F. **Do not use a torch!**
24. Install anti-lock tone wheel (if applicable) while hot onto the outside diameter of the differential ring gear flange as stated in the vehicle service manual.
25. Install the ring gear while hot onto the differential. It is advantageous to use pilot studs to align the ring gear to the differential as shown in Figure 5.

Figure 5



26. Using new ring gear bolts, alternately tighten each ring gear bolt to the proper torque:
 - 3/8" Bolts = 50 lb ft
 - 7/16" Bolts - 80 lb ft
 - 1/2" Bolts = 100 lb ft
27. For adjuster nuts, skip to Step 35.
28. Select two shims of approximately equal size whose total thickness is equal to the shim pack thickness determined in Step 21.
29. Place the differential assembly with the ring gear, bearing cups and shims into the differential housing. Install bearing caps and bolts in their proper position and tighten bolts. While tightening bearing cap bolts, continuously rock the ring gear back and forth to confirm backlash. If at any time the backlash becomes reduced to zero, remove bearing caps and adjust the shim packs by removing .010" from the ring gear side and adding .010" to the opposite side. Repeat as needed until both bearing caps can be torqued to the proper torque value and ring and pinion backlash is confirmed.

30. Rotate the differential case several revolutions to seat the bearings. Check the backlash as described in Step 6.
31. Compare the backlash reading to the original reading taken in Step 6 and adjust as needed. To increase backlash, remove shim thickness from the ring gear side and add an equal amount of shim thickness to the opposite side. To decrease backlash, add shim thickness to the ring gear side and remove an equal amount of shim thickness from the opposite side.

Note: Approximately .001" of shim equals .001" of backlash.

32. Once the correct backlash reading has been established, add .004" of shim thickness to both shim packs to preload the differential bearings. It will be necessary to drive the shims into position. Do not hit the bearing cups. It is advantageous to use a Case Spreader to install the differential.
33. Torque the bearing cap bolts to the proper value and rotate the differential case several revolutions to seat the bearings. Recheck the backlash and correct if necessary.
34. Skip to Step 47.
35. Place the differential assembly with ring gear and bearing cups into the differential carrier.
36. Apply a light coat of axle oil to the bearings and adjuster nut threads.
37. Install the bearing caps in their original position and hand tighten the bearing cap bolts.
38. Install the adjuster nuts (unless still in the differential housing) being careful not to cross thread the adjuster nuts causing thread damage.
39. With the adjuster nuts installed and the bearings in position, torque the bearing cap bolts to the proper torque value.
40. For Chrysler 8-1/4 and 9-1/4, skip to Step 46.
41. Loosen the RH adjuster nut (opposite the ring gear) until it is away from the bearing cup. Tighten the LH adjuster nut (ring gear side) until the ring gear is slightly forced into the drive pinion (zero backlash). Rotate the differential several revolutions to ensure no binding is present. Recheck RH adjuster nut to be sure that it is not against the RH bearing cup. Use an appropriate tool to turn adjuster nuts.
42. Install indicator as shown in Figure 6. Tighten RH adjuster nut until a case spread of .008 - .012 is measured. Rotate drive pinion several times in each direction to seat the bearings and to be sure that binding does not occur. It may be necessary to readjust the case spread by tightening the RH adjuster nut.
43. Measure the backlash as done in Step 6. If necessary, adjust the backlash until it matches the original reading taken in Step 6. Increase backlash by loosening the LH adjuster and tightening the RH adjuster the same amount. Decrease backlash by loosening the RH adjuster nut and tightening the LH adjuster nut the same amount. When making adjustments, always make the final adjustment in the tightening direction. For example, if the adjuster needs to be loosened one notch, loosen it two notches and tighten it one. When the proper backlash has been established, install the adjuster nut locks.

Figure 6

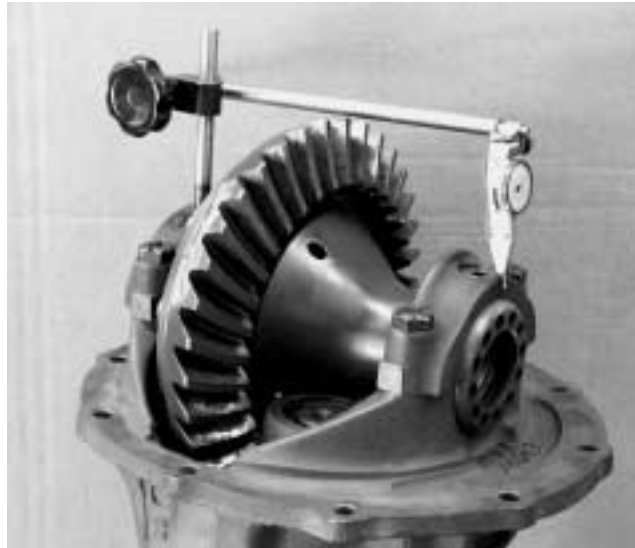

44. Install third member into axle housing using a new gasket or silicone sealer and tighten nuts. Reinstall drive shaft.
45. Skip to Step 47.
46. For Chrysler 8-1/4 and 9-1/4 applications, using tool C-4164, adjust the position of the differential until the proper backlash reading has been established. Refer to Step 6 for the backlash checking procedure and original backlash reading. Alternately tighten each adjuster nut and rotate the differential case several revolutions to seat the bearings. Being careful not to change the backlash, repeat until each adjuster nut has been tightened to 70 lb ft. Recheck backlash and correct if necessary. Install adjuster nut locks.
47. Install axle shafts into housing being careful not to damage the oil seals.
 - A. "C" clip axles
 - 1) Remove pinion shaft lock screw and pinion shaft.
 - 2) Push flanged end of axle shaft toward the center of the housing and install the "C" clip onto the button end of the axle shaft. Pull axle shaft outward so the shaft and washer seat in the counterbore of the side gear. Repeat for other axle shaft.
 - 3) Install pinion shaft through the case and pinions, aligning the hole in the shaft with the lock screw hole. Install lock screw and torque to 20 - 25 lb ft.
 - B. Non-"C" clip axles
 - 1) Install axle shaft bearing retaining plate and nuts. Tighten nuts to proper torque.

Note: Some axles use shims or adjuster nuts to set the axle shaft end play. Refer to the vehicle service manual for the proper removal and installation procedures for the axle shafts.
48. Using a new gasket or silicone sealant, install axle cover and tighten bolts.
49. Install brake drums or rotors.

- 50. Install wheels.
- 51. With the vehicle level, remove the fill plug and fill housing to the proper level with the **lubricant** and **additive** described on **page 2**.
- 52. Lower vehicle and test operation of axle.

FOR YOUR RECORDS – retain your original receipt for Replacement/Exchange Program

Differential Part Number: _____

Purchased From: _____

Phone No.: _____

Date Installed: _____

Installed By: _____

Phone No. _____

Vehicle Mileage: _____

NOTES:

**AUBURN GEAR, INC.
LIMITED-SLIP DIFFERENTIAL
LIMITED WARRANTY AND REMEDY**

LIMITED WARRANTY

Auburn Gear, Inc. ("Manufacturer") warrants that this product is free from defects in materials and workmanship for a period of one (1) year after purchase by the consumer, or 12,000 miles of normal use by the consumer, whichever is less; provided that this product:

- has been installed and maintained in accordance with the Manufacturer's instructions; and
- has been used in regular automotive driving and not in any off-road application; and
- has been used with the proper lubricant and additive, as specified in the installation instructions at all times; and
- has not been subject to modification, accident, or misuse.

This limited warranty is the sole express warranty provided by manufacturer to the ultimate user of the product. The manufacturer disclaims all other express warranties, and all implied warranties, including the implied warranties of merchantability and fitness for a particular purpose.

EXCLUSIVE REMEDY

In the event of a breach of this warranty, you shall return the product to the seller within thirty (30) days after the expiration of the limited warranty period, along with your proof of purchase and explanation of the defect. Seller or Manufacturer may investigate the claim of defect, and in the event of a defect in the product shall, at their election, either repair the defective product, replace the defective product with a new product, or refund the purchase price. These remedies are your sole and exclusive remedies in the event of a breach of warranty.

LIMITATION OF LIABILITY FOR DAMAGES

In no event shall Manufacturer be liable for consequential, special, indirect, or exemplary damages, whether based upon tort, contract, warranty, negligence, strict liability, or other legal theory. Manufacturer's liability shall be limited to direct damages.

EXCEPTIONS TO LIMITED WARRANTY AND REMEDY

This limited warranty and remedy gives you specific legal rights. You may have other statutory rights in states that do not allow the limitation on or exclusion of certain warranties or remedies.

Auburn Gear, Inc.
400 East Auburn Drive
Auburn, IN 46706
TEL: 260 925 3200
FAX: 260 925 4725
E-mail: agdiffs@auburngear.com
Web: www.auburngear.com

MH 553
LSI-2001